



TELEDYNE INSTRUMENTS
Monitor Labs
A Teledyne Technologies Company

sensor^e[®]

**Gas Filter Correlation CO₂ Analyzer
TML20M (Mid-Range)**

0-4 ppm to 0-4000 ppm, user selectable

Gas Filter Wheel for CO₂ specific measurement

GFC wheel guaranteed against leaks for five years

Multi-tasking software allows viewing test variables while operating

Continuous self checking with warning alarms

Ethernet and RS232 ports for remote operation

Digital status outputs provide instrument condition

Adaptive signal filtering optimizes response time

Temperature and Pressure compensation

Internal data logging with 1 minute to 24 hour averages

Sensor-e.com remote operation software



The sensor-e[®] CO₂ measures carbon dioxide by comparing infrared energy absorbed by a sample to that absorbed by a reference gas according to the Beer-Lambert law. This is accomplished with a Gas Filter wheel which alternately allows a high energy infrared light source to pass through a CO₂ filled chamber and a chamber with no CO₂ present.

The light then travels through the sample cell, which has a folded path. The energy loss through the sample cell is compared with the zero reference signal provided by the gas filter to produce an output proportional to concentration, with little effect from interfering gases within the sample.

This design produces superior zero and span stability and a high signal to noise ratio allowing extreme sensitivity. Multi-tasking software gives real time indication of numerous operating parameters and provides automatic alarms if diagnostic limits are exceeded.

Built-in-data acquisition and internal memory allows logging multiple parameters including average and instantaneous values, calibration data and operating parameters. Over 500,000 records of stored data can be retrieved via the Ethernet port or from the front panel.

The sensor-e[®] CO₂ features rugged construction and is designed to perform with minimum attention. Regular maintenance is greatly simplified through the use of modular construction.



sensor-e®

Gas Filter Correlation CO₂ Analyzer TML20M (Mid-Range)

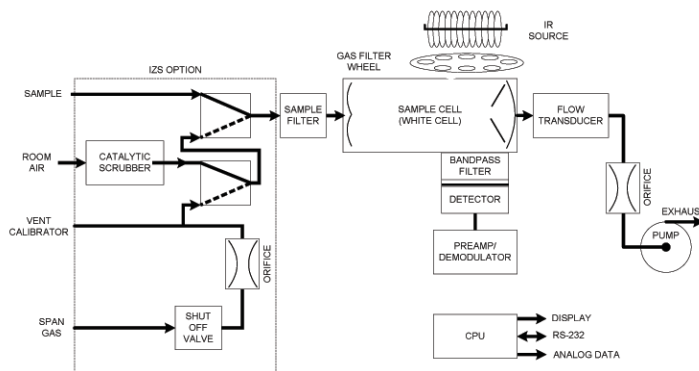

SPECIFICATIONS

Model:	TML-20M
Ranges:	0-4ppm to 0-4,000 ppm full scale, user selectable
Other Ranges Available:	Dual ranges and autoranging supported.
Units:	ppb, ppm, $\mu\text{g}/\text{m}^3$, mg/m^3
Zero Noise:	<0.2 ppm
Span Noise:	<1.0% of reading above 20 ppm (RMS)
Lower Detectable Limit (LDL):	0.4 ppm
Zero Drift:	<0.5 ppm/24 hours, <1ppm/7 days
Span Drift:	<0.5% reading/24 hours, 1% reading/7 days
Lag Time:	10 seconds
Rise and Fall Time:	<60 seconds to 95%
Linearity:	1% of full scale
Precision:	0.5% of reading
Sample Flow Rate:	800cc/min \pm 10%
Operating Temperature Range:	5 - 40°C

Dimensions (HxWxD):	7" (178 mm) x 17" (432mm) x 25" (597 mm)
Weight:	52 lbs (24.0Kg)
Power:	100V, 50/60Hz, 115V, 60Hz, 220 50/60Hz, 230V, 50Hz, 240V, 50Hz, 250 Watts
Analog Outputs:	Bi-polar, 10V, 5V, 1V, 100 mV, selectable \pm 10%
Recorder Offset:	
Serial Port 1:	RS-232, DB-9M/RS485 optional
Serial Port 2:	Ethernet
Status (Digital):	12 outputs and 3 inputs (opto-isolated)
Current Output:	Specify up to three channels
Approvals:	CE

NOTE: The values expressed above are in accordance with EPA definitions. All error specifications are based on constant conditions.

sensor-e® CO₂ Analyzers include:

- * Internal pump
- * Auto ranging and dual ranges
- * 5 micron filter
- * 8 digital status outputs, 6 inputs
- * Multi-drop RS-232 connection
- * Ethernet Port
- * Sensor-e.com software

Supported voltages:

- 100V
- 220V - 240V
- 115V

Selectable voltage:

- 100v/50hz
- 220V - 50hz
- 230V/50hz (CE)
- 240V/50hz
- 100v/60hz
- 115V/60hz
- 220V/60hz

Selectable output voltage:

- 10V
- 5V
- 1V
- 100mV

Additional Options:

- RS-485 communications
- 4-20 mA output

Accessories:

- RS-232 Cable
- Expendables Kit
- Spare Parts Kit
- Rack Mount Slides